

CAD FILE:

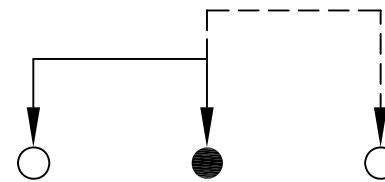

SCHEMATIC (SHORTING)

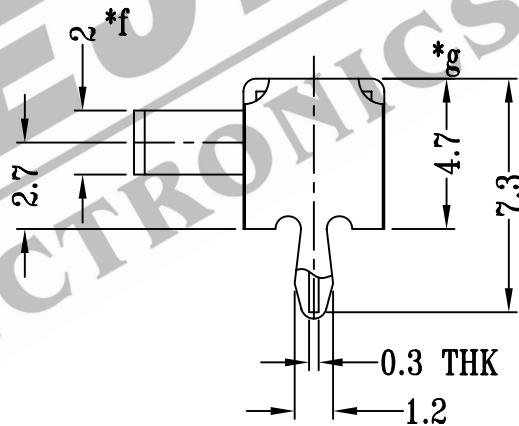
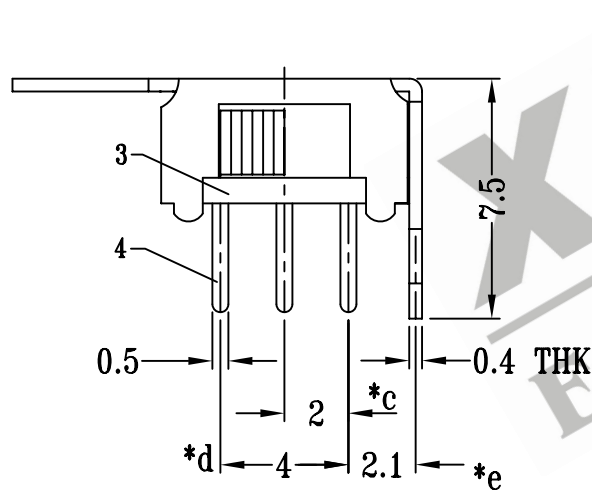
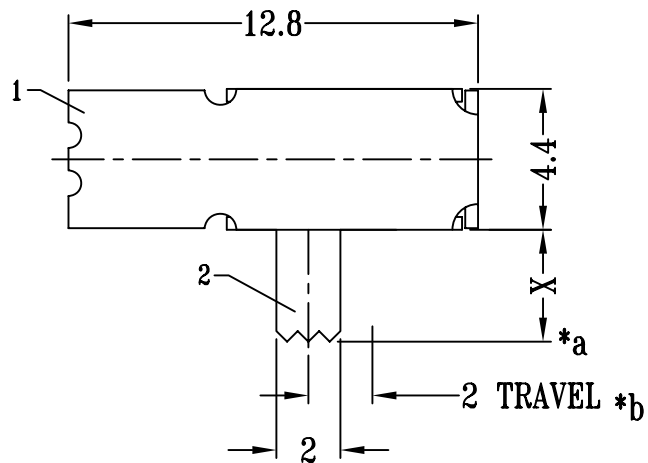
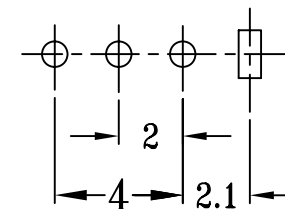

P.C.B LAYOUT

注:带"*"表示关键尺寸(7个)

NO.	PARTS	MATERIALS	Q'TY	FINISH	TOLERANCE UNLESS SPECIFIED	SHENZHEN XIEJIA ELECTRONICS CO.,LTD.																										
8						<table border="1"> <tr> <td>ISSUE</td> <td>DATE</td> <td colspan="2">DESCRIPTIONS OF REVISION</td> <td>APPD.</td> </tr> </table>				ISSUE	DATE	DESCRIPTIONS OF REVISION		APPD.																		
ISSUE	DATE	DESCRIPTIONS OF REVISION		APPD.																												
7																																
6	SPRING PLATE	STAINLESS STEEL	1	NATURAL	WITHIN: 1.5±0.1mm OVER: 1.5±0.2mm	<table border="1"> <tr> <td colspan="2">TITLE : HORIZONTAL SLIDE SWITCH</td> <td>UNIT : mm</td> <td colspan="2">DRWG NO.: XJ-DR-SK12D07-00</td> </tr> <tr> <td colspan="2">MODEL: SK-12D07</td> <td>SCALE: 4:1</td> <td>DWN.</td> <td>ZHOUYU</td> <td>2003-1-21</td> </tr> <tr> <td colspan="2"></td> <td></td> <td>CHK'D</td> <td>FANGYING</td> <td>2003-1-21</td> </tr> <tr> <td colspan="2"></td> <td></td> <td>APPD.</td> <td>KANGXINAN</td> <td>2003-1-21</td> </tr> </table>				TITLE : HORIZONTAL SLIDE SWITCH		UNIT : mm	DRWG NO.: XJ-DR-SK12D07-00		MODEL: SK-12D07		SCALE: 4:1	DWN.	ZHOUYU	2003-1-21				CHK'D	FANGYING	2003-1-21				APPD.	KANGXINAN	2003-1-21
TITLE : HORIZONTAL SLIDE SWITCH		UNIT : mm	DRWG NO.: XJ-DR-SK12D07-00																													
MODEL: SK-12D07		SCALE: 4:1	DWN.	ZHOUYU	2003-1-21																											
			CHK'D	FANGYING	2003-1-21																											
			APPD.	KANGXINAN	2003-1-21																											
5	CONTACT CLIP	PBS	1	Ag CLAD																												
4	TERMINAL	BRASS STRIP	3	Ag PLATED OVER Ni PLATED																												
3	BASE	PHENOLIC RESIN	1	NATURAL																												
2	KNOB	POM	1	BLACK																												
1	FRAME	STEEL STRIP	1	Ni PLATED																												
					ALL MATERIALS MUST BE COMPLIANT TO ROHS																											